

Technical Datasheet

Overview

- Compatible with SQ, Qu, Avantis, AHM-64, GLD
- 16 Mic Preamps on XLR
- Phantom Power LED per Input
- 8 XLR Line Outs
- dSNAKE Connection with locking Ethercon port
- Additional locking Ethercon port for daisy chaining / ME personal mixing system
- Rubber bumpers
- Carry handle
- Optional rack mount kit available

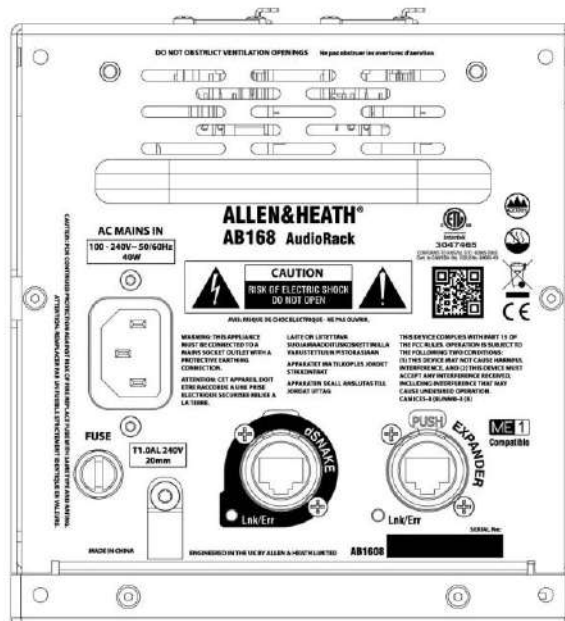
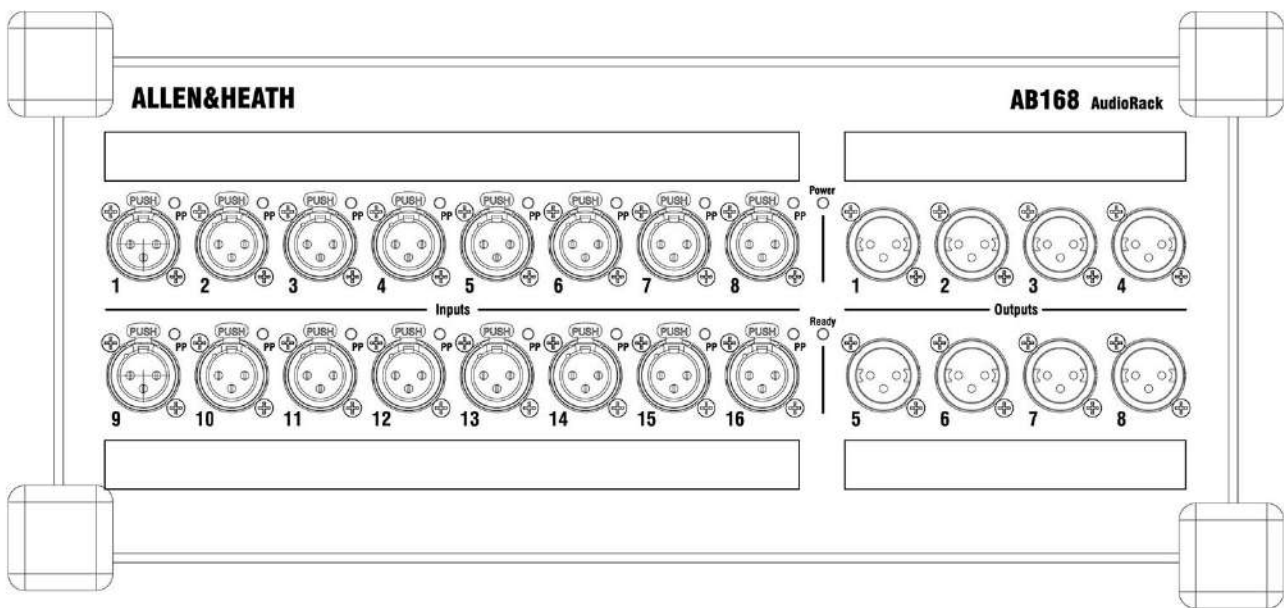

Dimensions

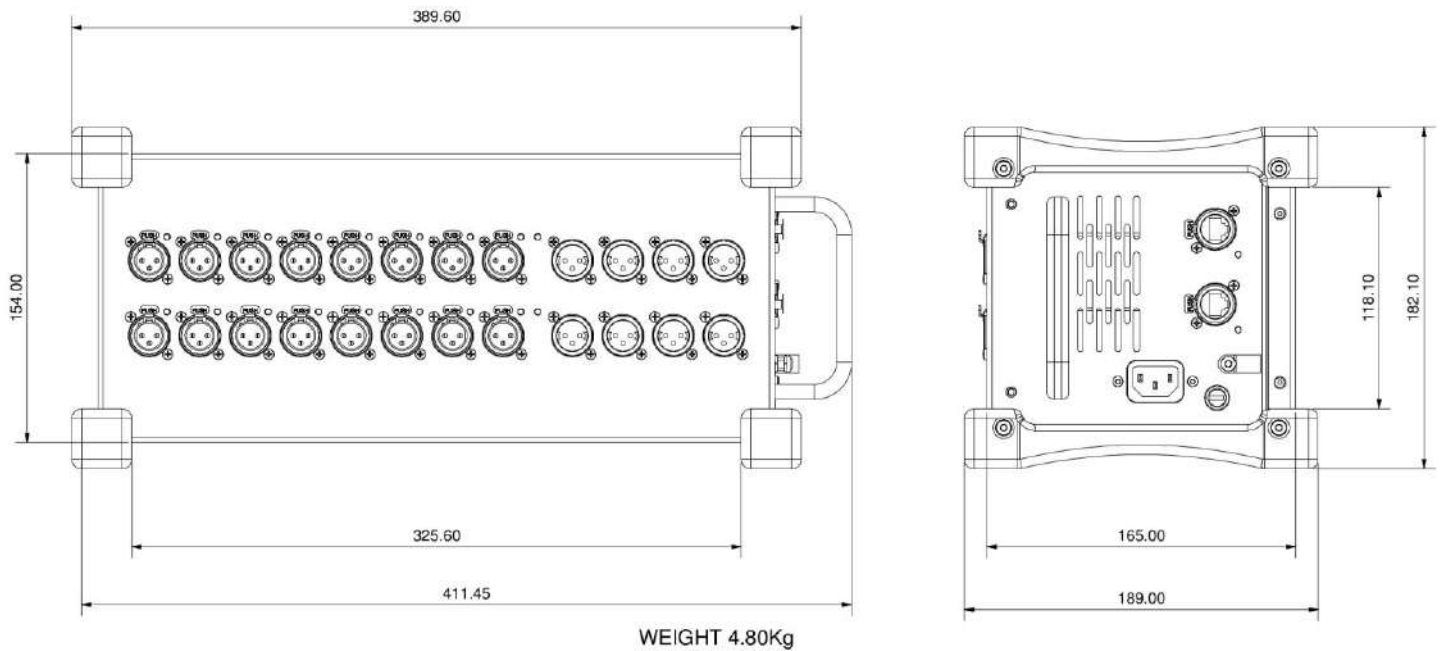

A&E Specifications

The unit shall be a portable remote audio rack for a digital mixing system. The remote audio rack shall provide 16 XLR inputs and 8 XLR outputs and shall be connected to add a further inputs and outputs. The XLR sockets shall be the same or higher quality and specification as those located on the digital mixing system, and shall appear in the digital mixing system soft patch for assignment to channels.

Audio connection shall be over Cat5 cable using Allen & Heath's dSNAKE Ethernet protocol, allowing the remote audio rack to be positioned up to 100m from the mixer or expanded audio rack. The Ethernet protocol shall provide control to the remote preamp, and all mic preamps are scene recallable by the digital mixing system. Phantom power LED indicators shall be provided per input socket on the remote audio rack. Unit firmware shall automatically be updated when connected to the digital mixing system. The local Ethernet port shall be an RJ45 socket with EtherCon locking ring.

It shall also be possible to connected the remote audio rack to a main AudioRack unit to add a further 16 XLR inputs and 8 XLR outputs from that location. This connection shall be via an 'Expander' connection and shall also be an RJ45 socket with EtherCon locking ring.

The remote audio rack shall provide an 'Expander' port to allow the connection of an additional remote audio rack from that location. This connection shall also be a 'dSNAKE' RJ45 socket with EtherCon locking ring. This port shall also provide 40 channels to Allen&Heath ME personal monitoring solution hardware and the remote audio rack shall be compatible with Allen&Heath digital mixers.

The remote audio rack shall have a robust steel chassis and shall be designed to be portable and to be placed horizontally or vertically on the stage or performance environment. A carrying handle shall be provided to facilitate

lifting and holding the device when moving and an optional padded dust cover shall be available. The remote audio rack shall also be mounted in a 19" equipment rack or case using an optional remote audio rack kit.

The remote audio rack shall have a built in power supply accepting AC mains voltages of 100~240V, 50/60 Hz, 40W max via an earthed 3-pin IEC male connector mounted on the rear chassis.

Recommended operating temperature for the remote audio rack shall be 5 to 35 degrees Celsius.

The unit shall be the Allen&Heath AB168 Portable AudioRack.

System Specifications

Inputs

XLR Mic/Line Inputs	Balanced
Mic/Line Preamp	Fully recallable
Input Sensitivity	-60 to +15dBu
Analogue Gain	+5 to +60dB, 1dB steps
Pad	-20dB
Maximum Input Level	+32dBu
Input Impedance	>4k Ω (Pad out), >10k Ω (Pad in)
Mic/Line Channel noise	20-20kHz, Direct Out @ unbalanced out
Mic EIN	-127dB with 150 Ω source
Unity gain (Pad in)	-90dBu
Low gain (5dB, Pad out)	-93dBu
Mid gain (30dB, Pad out)	-89dBu
Mic/Line Channel THD+N	20-20kHz, Direct Out @ unbalanced out
Unity gain (Pad in)	0.005% -86dBu @ 1kHz, 0dBu output
Low gain (5dB, Pad out)	0.003% -89dBu @ 1kHz, 0dBu output
Mid gain (30dB, Pad out)	0.004% -88dBu @ 1kHz, 0dBu output

Outputs

XLR Outputs	Balanced, Relay protected
Output Impedance	<75 Ω
Nominal Output	+4dBu = 0dB meter reading
Maximum Output Level	+22dBu
Residual Output Noise	-91dBu (muted, 20-20kHz)
Operating Temperature	0 deg C to 35 deg C (32 deg F to 95 deg F)
Mains Power	100-240V, 50/60 Hz, 40W max